

L2-ENC28-WH-A

Enclosure Wiring Harness for 1-4 PDM & AC/DC Supply

The wiring harness provides DC power to the PDMs in the enclosure.

Connects these devices:

- 1 600/1000W Power Supply
- 1-4 PDM (3 first, 1 second)
- 1 AC Outlet to Power Supply

Partially Assembled Kit Includes:

- 4 PDM Fuses with Negative PassThru
- 8 #12 AWG wires from Fuses to PDM
- 4 #10 AWG wires from PS to Fuses
- 1 Accessory Fuse w/Negative PassThru
- 2 5 position power bus bars
- 4 PDM wire end insulators
- 1 6.5cm DIN
- 1 AC Ground Lug w/self tap screw
- 1 NEMA 5-15 Right Angle AC

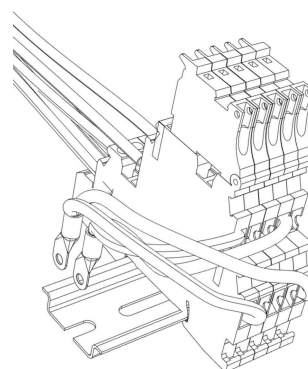
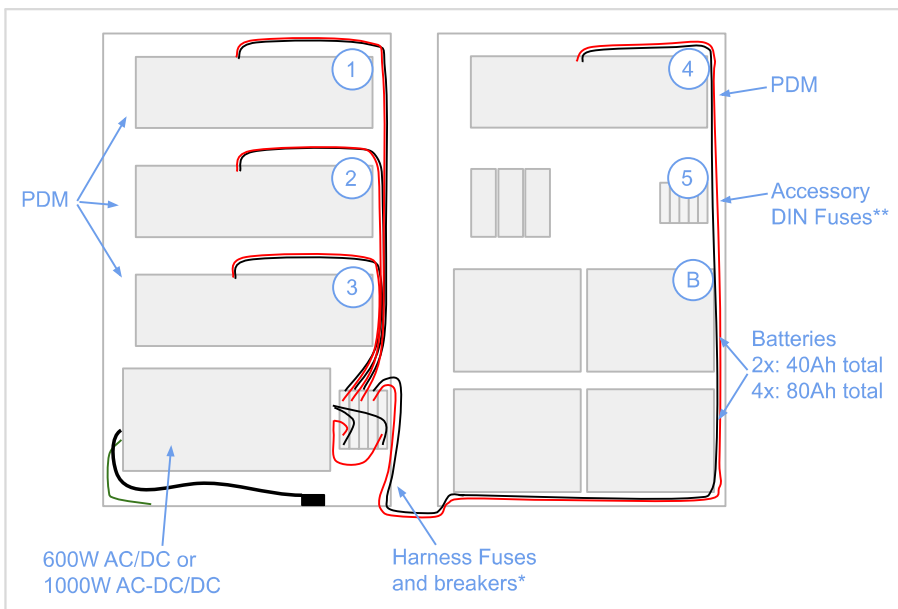

Circuit Diagram:

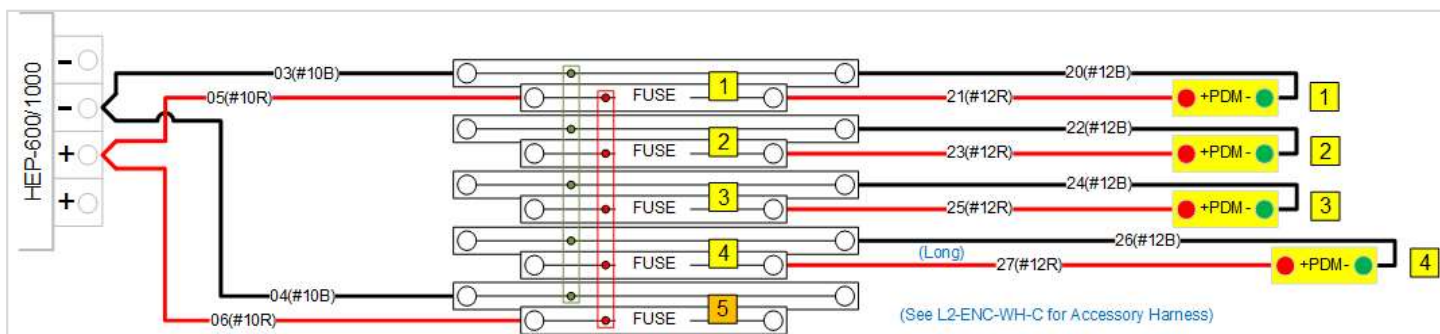

ORDERING INSTRUCTIONS:

PART ID	MODEL	DESCRIPTION
10010250.0	L2-ENC28-WH-A	Enclosure Wiring Harness for 1-4 PDM & AC/DC Supply



L2-ENC28-WH-A

WIRE MAP:

WIRE	AWG	LENGTH	END	DEVICE
03	#10 BLK	29cm	Strip-10mm, Ring#8-3M	PS- / Fuse-PassThru
04	#10 BLK	28cm	Strip-10mm, Ring#8-3M	PS- / Fuse-PassThru
05	#10 RED	22cm	Strip-10mm, Ring#8-3M	PS+ / Fuse+
06	#10 RED	25cm	Strip-10mm, Ring#8-3M	PS+ / Fuse+
20	#12 BLK	85cm	Strip-10mm, Strip-6mm	Fuse-PassThru / PDM-
21	#12 RED	88cm	Strip-10mm, Strip-6mm	Fuse+ / PDM+
22	#12 BLK	116cm	Strip-10mm, Strip-6mm	Fuse-PassThru / PDM-
23	#12 RED	120cm	Strip-10mm, Strip-6mm	Fuse+ / PDM+
24	#12 BLK	149cm	Strip-10mm, Strip-6mm	Fuse-PassThru / PDM-
25	#12 RED	152cm	Strip-10mm, Strip-6mm	Fuse+ / PDM+
26	#12 BLK	376cm	Strip-10mm, Strip-6mm	Fuse-PassThru / PDM-
27	#12 RED	350cm	Strip-10mm, Strip-6mm	Fuse+ / PDM+
G	#18 GRN	57cm	Ring#12-3M, Strip-8mm	PS Ground / Enclosure

DIN MODULES INCLUDED IN HARNESS:

QTY	PART#	MODEL	DESCRIPTION
5	3214325	UT-4-L-HESI-5X20	2 Layer Fuse and PassThru
2	3030349	FBS-5-6	Bridge 5pos 6.3mm Red
2	0800886	E/NS 35 N	Locking End Cap
1			DIN Rail, 35mm x 6.5cm

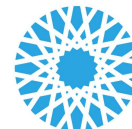

L2-ENC28-WH-B

Enclosure Wiring Harness for 1-4 Batteries

The battery wiring harness connects the AC/DC power supply to 2-4 batteries in the same or an adjacent enclosure.

Connects these devices:

- 1 600/1000W Power Supply
- 2,4 12V Batteries in 2 configurations

Partially Assembled Kit Includes:

- 1 6.5cm DIN
- 1 60A DC Battery Breaker
- 1 Battery Negative PassThru
- 2 #6 AWG wires from Power Supply
- 2 #6 AWG wires to Battery
- 4 #6 AWG Battery to Battery wires

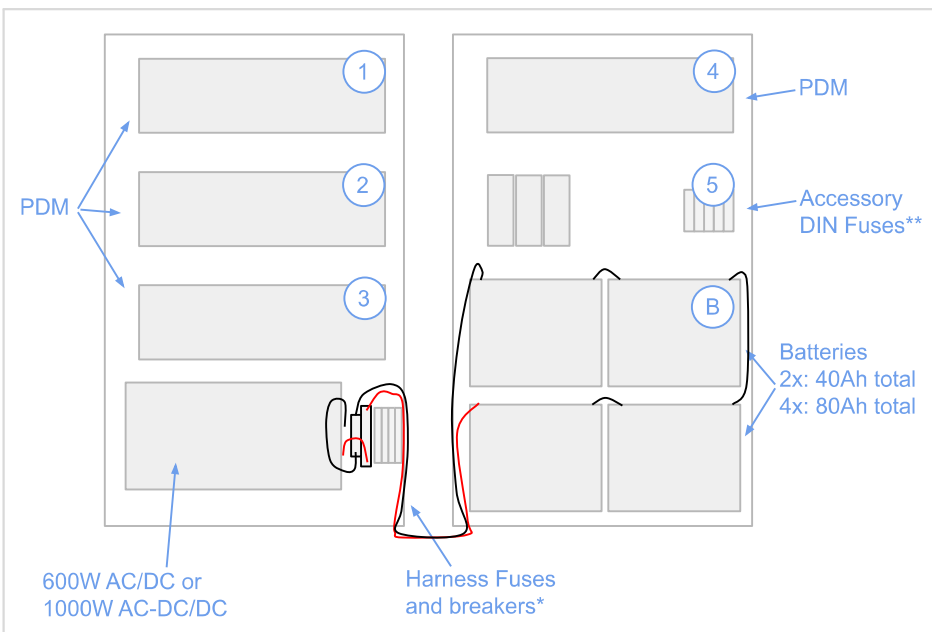

Circuit Diagram Configuration "A": 48V Battery Array

Battery Array

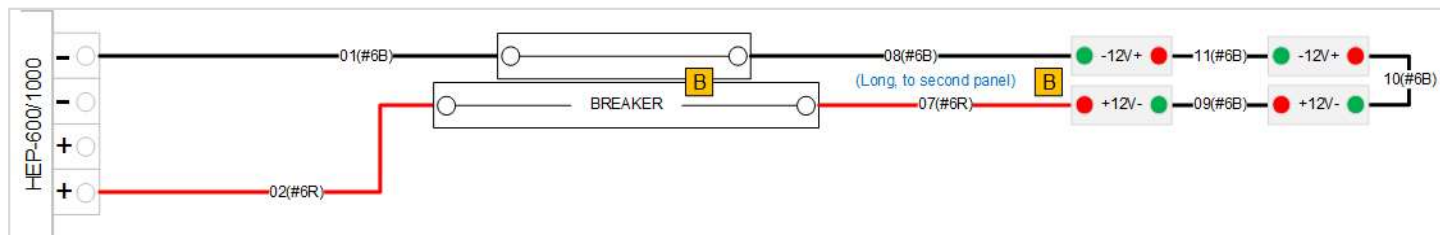

Circuit Diagram Configuration "B": 24V Battery Array

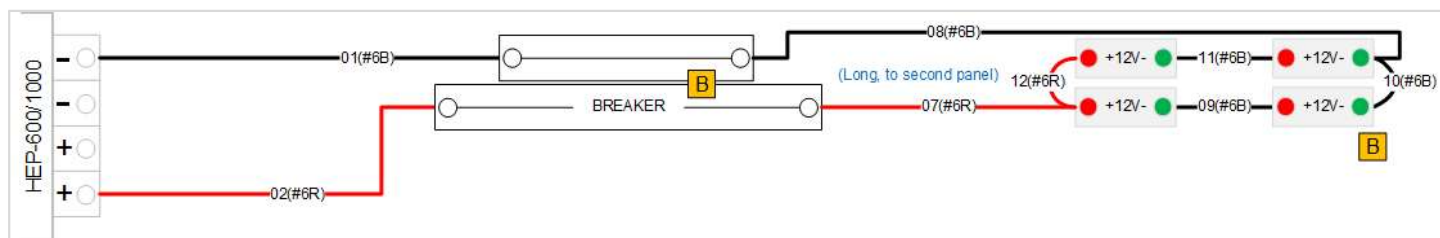

ORDERING INSTRUCTIONS:

PART ID	MODEL	DESCRIPTION
10010251.0	L2-ENC28-WH-B	Enclosure Wiring Harness for 1-4 Batteries

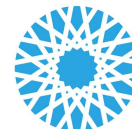

L2-ENC28-WH-B

WIRE MAP:

WIRE	AWG	LENGTH	TERMINATIONS	CONNECTS
01	#6 BLK	17cm	Strip-10mm, Ring#4-3M	PS- / PassThru
02	#6 RED	19cm	Strip-10mm, Ring#4-3M	PS+ / Breaker
07	#6 RED	261cm	Strip-10mm, Ring#4-3M	PS+ / Battery+
08	#6 BLK	244cm	Strip-10mm, Ring#4-3M	PS- / Battery-
09	#6 BLK	24cm	Ring#4-3M, Ring#4-3M	Battery+ / Battery-
10	#6 BLK	70cm	Ring#4-3M, Ring#4-3M	Battery+ / Battery-
11	#6 BLK	24cm	Ring#4-3M, Ring#4-3M	Battery+ / Battery-
12*	#6 RED	70cm	Ring#4-3M, Ring#4-3M	Battery+ / Battery-

* Use Wire 12 only when connecting 4 batteries in 24V array configuration "B"

DIN MODULES INCLUDED IN HARNESS:

QTY	PART#	MODEL	DESCRIPTION
1	3044197	UT 16 BK	Feed Thru (#4 wire capacity)
1	MNEPV60	MNEPV60	60A DC Breaker
1			DIN Rail, 35mm x 6.5cm

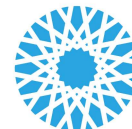

L2-ENC28-WH-C

Enclosure Wiring Harness for Expansion DIN Fuse Block

The wiring harness provides DC power and protection to accessory devices. The kit includes a wide DIN rail.

Connects these devices:

Feed Fuse (included in L2-ENC28-WH-A)

1-5 Accessory Fuse Blocks

Partially Assembled Kit Includes:

- 2 #12 AWG wires to Accessory Fuses
- 5 Accessory Fuses w/ Negative PassThru
- 5 Accessory Fuse Blocks
- 2 5 position power bus bars
- 1 35cm DIN

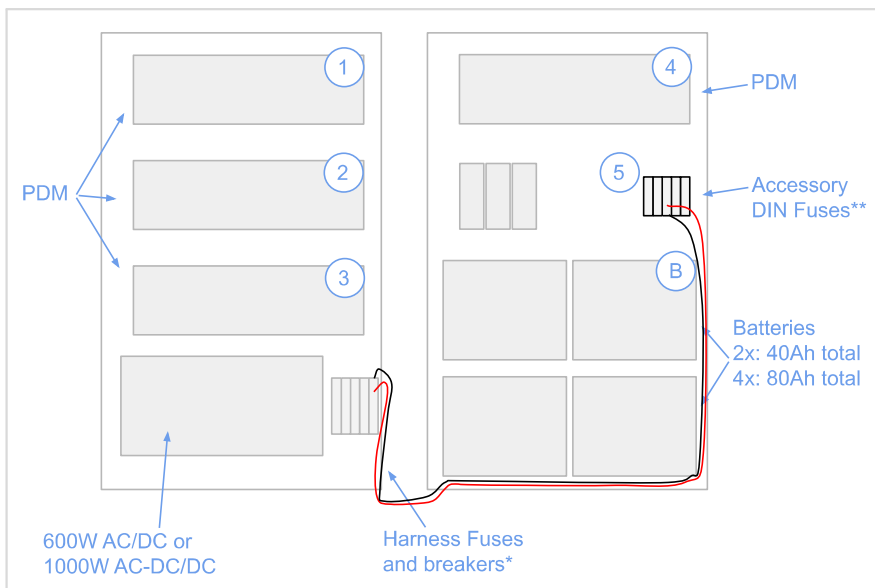

Circuit Diagram:

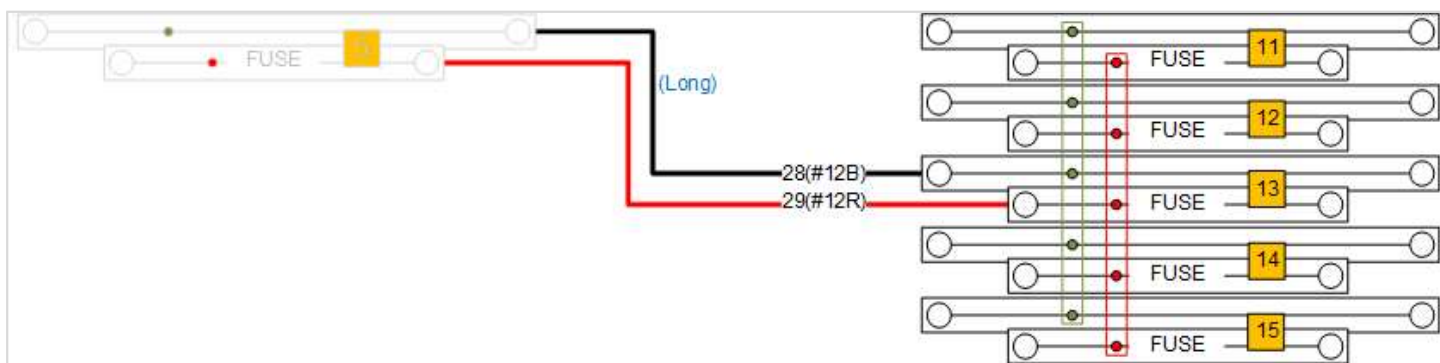

ORDERING INSTRUCTIONS:

PART ID	MODEL	DESCRIPTION
10010252.0	L2-ENC28-WH-C	Enclosure Wiring Harness for Expansion DIN Fuse Block

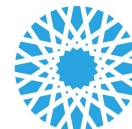

L2-ENC28-WH-C

WIRE MAP:

<u>WIRE</u>	<u>AWG</u>	<u>LENGTH</u>	<u>TERMINATIONS</u>	<u>CONNECTS</u>
28	#12 BLK	265cm	Strip-10mm, Strip-6mm	Fuse-PassThru / Accessory Fuse-PassThru
29	#12 RED	257cm	Strip-10mm, Strip-6mm	Fuse+ / Accessory Fuse+

DIN MODULES INCLUDED IN HARNESS:

<u>QTY</u>	<u>PART#</u>	<u>MODEL</u>	<u>DESCRIPTION</u>
5	3214325	UT-4-L-HESI-5X20	2 Layer Fuse and PassThru
2	3030349	FBS-5-6	Bridge 5pos 6.3mm Red
2	0800886	E/NS 35 N	Locking End Cap
1			DIN Rail, 35mm x 35cm